



Digital PID
Temperature Controller

Temperature Controllers



ESD-9950-N



- ▶ Adjustable temperature offset
- ▶ Programmable control and alarm functions for control outputs

- ▶ Programmable ON-OFF, P, PI, PD, PID control forms
- ▶ With Auto Tune / Self Tune operation, the PID coefficients adaptation to the system

Specifications

- 4 Digits display
- J type Thermocouple Input or
- K type Thermocouple Input or
- R type Thermocouple Input or
- S type Thermocouple Input or
- 2 or 3 wire PT 100 Input

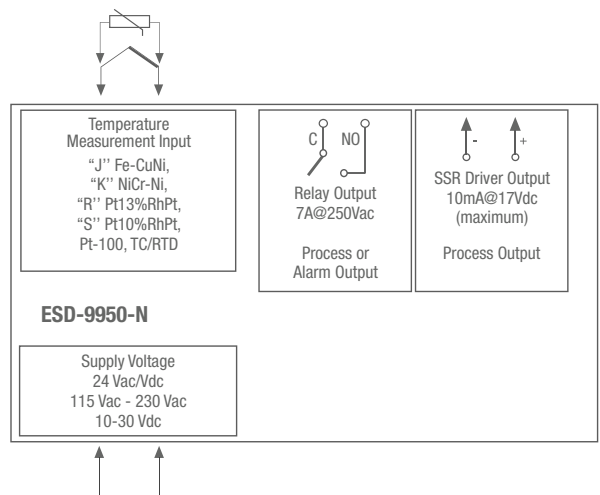

Technical Specification

- Accuracy:** $\pm 25\%$ of scale
- Cold Junction Compensation:** Automatically $\pm 0.1^\circ\text{C}/1^\circ\text{C}$
- Sensor Break Protection:** Upscale
- Sampling Cycle:** 10 samples per second

